

Private pools

In-ground swimming pools

The Borough of Saint-Laurent has adopted regulations to guide the installation of private swimming pools and all related accessories in order to ensure that this type of equipment provides safe conditions to its users.

A certificate of authorization from the Borough is required prior to constructing, installing or removing an in-ground swimming pool.

Process

To submit a request for an authorization certificate, the form, "Application for a certificate of authorization for an above-ground or an inground swimming pool or a hot tub (spa)", must be filled in and attached to the required documents. These documents must be submitted to the Division des permis et des inspections, located at 777, boulevard Marcel-Laurin.

Costs

Fees are required to process a request.

Location

In-ground pools are permitted at the following locations:

- Secondary front yard in the case of a corner lot (figure 1)
- Side yard
- Rear yard (figure 2)

Additional provisions

- A minimum distance of 1.5 m between the interior wall of the pool and a building or a lot line must be respected.
- In the case of a private swimming pool located in the secondary front yard, a hedge must be planted along the lot line running along the street.
- The installation of a swimming pool below an electrical wire or line is prohibited.

Fencing

- A fence, with a minimum height of 1.5 m, must be installed around an in-ground pool.
- An in-ground pool may be bounded by a building wall without any direct access to the exterior.
- A fence, with a minimum height of 1.2 m, must separate any in-ground pool from the wall of a main building with direct access to the pool.
- Fences must be installed at least 1.5 m from an in-ground pool.

Characteristics (figure 3)

- The fence gate must have a locking mechanism and remain locked at all times.
- A minimum distance of 1.5 m between the interior wall of the in-ground pool and the fence must be respected.

- Openings in the fence must be no bigger than 7 cm.
- Horizontal fence rails must be separated by at least 1 m.
- The space between the fence and the ground cannot be more than 7 cm in height.

Figure 1: Location of an in-ground pool (spa) on a corner lot.

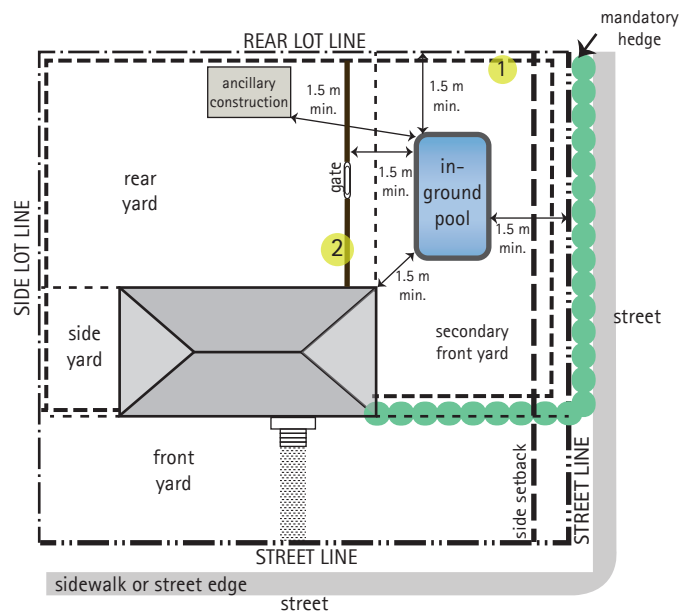

- 1 minimum fence height: 1.5 m 2 minimum fence height: 1.2 m

Figure 2: Location of an in-ground swimming pool in a rear yard

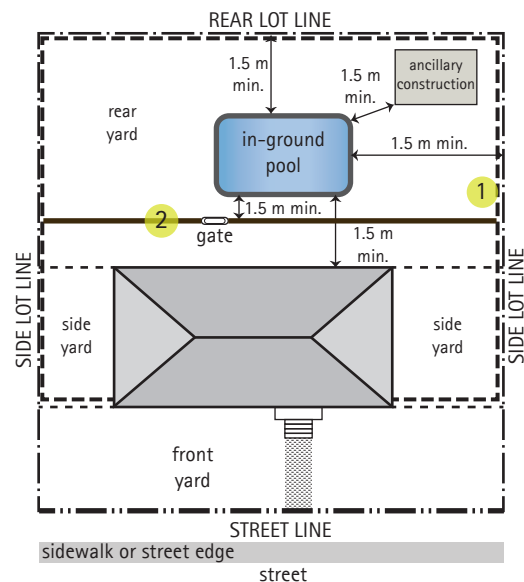

- 1 minimum fence height: 1.5 m 2 minimum fence height: 1.2 m



Figure 3: Characteristics of a fence around an in-ground pool

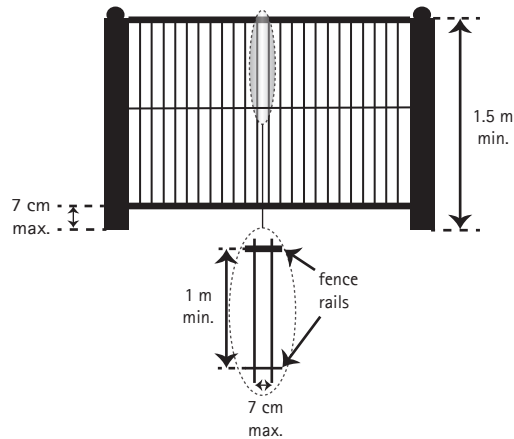

Equipment and accessories

- The maximum height for accessories and equipment is 3 m.
- An in-ground pool may be equipped with a diving board provided the following provisions are respected:
 - Pool depth must be at least 3 m.
 - The diving board must be installed at the deep end of the pool.
 - The maximum height of the diving board is 1 m above the water surface.
- A minimum distance of 1.5 m between any equipment or accessory and any lot line must be respected.

Gas tank (figure 4)

The installation of a gas tank for gas water heaters is permitted provided the following provisions are respected:

Location

- In the side yard and side setback
- In the rear yard and rear setback
- In the rear yard and front setback in the case of a transverse lot*

* A lot fronting on 2 parallel streets.

Conditions

- The gas tank must be surrounded by a high or low wall, or a fence with a minimum height of 1.5 m, so that it is not visible from the street.
- The maximum height of a gas tank is 2 m.
- The maximum distance between the gas tank and the adjacent wall of the main building is 2 m.
- A maximum encroachment of 2 m on a setback is permitted.
- The minimum distance between the gas tank and any lot line is 2 m. In the case of a side yard and side setback, the minimum distance is 75 cm.

Figure 4: Location of a gas tank

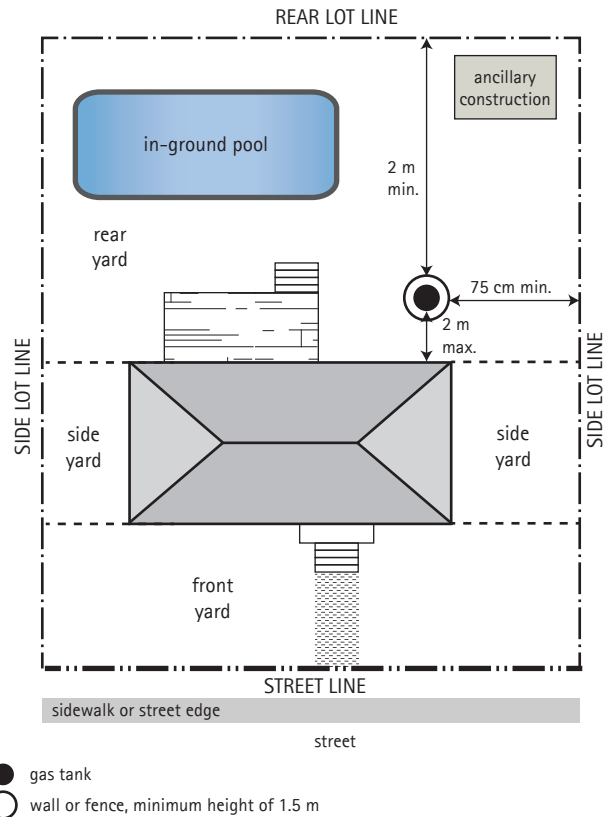

- gas tank
- wall or fence, minimum height of 1.5 m

Lighting

The installation of an above-ground lighting system is permitted if the following provisions are respected:

- The electrical power must be fed underground.
- The light source must only illuminate the lot on which the pool is located.

Walking area

The walking area around an in-ground pool must have a non-skid surface.

IMPORTANT: Depending on their nature and magnitude, certain construction projects may require obtaining a permit to occupy the public domain, particularly due to the installation of a container, a debris chute or the presence of materials on public roads. For more information, consult the information sheet, "Regulation: Occupation of the public domain".

 Information: 311 - ville.montreal.qc.ca/saint-laurent/infosheets

Legal framework: Règlement sur le zonage n° RCA08-08-0001
Règlement sur les tarifs n° RCA14-08-1

Notice: Certain specific provisions, not mentioned in this document, may apply. This information sheet has been prepared for the convenience of the reader and has no official status. Text accuracy is not guaranteed. For legal purposes, consult the official French version of the bylaw and all its amendments.

**APPLICATION FOR A CERTIFICATE OF
AUTHORIZATION FOR AN ABOVE-GROUND OR AN
INGROUND SWIMMING POOL OR A HOT-TUB (SPA)**

All fields must be completed and all required documents must be provided and payment made on the date the application is submitted. Incomplete applications will not be considered.

Note that zoning clauses must be checked: the zoning Bylaw RCA08-08-0001 and the provincial regulations on swimming pools/hot-tubs

REQUIRED DOCUMENTS

<input type="checkbox"/>	2 copies of the site plan indicating the position of the swimming pool/hot-tub on the property, and also indicating the distance between the swimming pool/spa and the property lines, the building, and the fences. Indicate the locations of all accessory equipment such as water heater, filter, fences (type and height), platform and paved surfaces, and the trees on the property and adjacent properties.
<input type="checkbox"/>	2 copies of the certificate of location, to scale.
<input type="checkbox"/>	2 copies of the construction details for an above-ground swimming pool platform, if applicable.
<input type="checkbox"/>	The form for the "Application for a certificate of authorization for tree cutting", if applicable.
<input type="checkbox"/>	A cheque payable to Ville de Montréal for the amount of: \$76 for an above-ground swimming pool or hot-tub; \$305 for an inground or semi-inground swimming pool.

1. GENERAL INFORMATION

Address of the property	
Type of application <input type="checkbox"/> New construction <input type="checkbox"/> Relocation <input type="checkbox"/> Removal	Work value
Type of pool or hot-tub <input type="checkbox"/> Above-ground pool <input type="checkbox"/> Inground pool <input type="checkbox"/> Semi-inground pool <input type="checkbox"/> Hot-tub	Scheduled work date

2. NAME OF BUILDING OWNER OR MANAGER

Name of owner or manager	Contact person
Complete address	Postal code
Telephone	Email address

3. NAME OF CONTRACTOR

Name of contractor	Telephone
--------------------	-----------

4. APPLICANT

Name	Contact person
Complete address	Postal code
Telephone	Email address

5. SIGNATURE

I certify that all of the information I have provided is accurate.	
I acknowledge that any error or omission could result in the cancellation of this application and of the certificate.	
First and last names	
Signature	Date

A L'USAGE DU BUREAU SEULEMENT		
Approuvé par	Approbation en date	Numéro du certificat d'autorisation