

# Private pools

## Above-ground swimming pools

The Borough of Saint-Laurent has adopted regulations to guide the installation of private swimming pools and all related accessories in order to ensure that this type of equipment provides safe conditions to its users.

A certificate of authorization from the Borough is required prior to constructing, installing or removing an above-ground swimming pool.

### Process

To submit a request for an authorization certificate, the form, "Application for a certificate of authorization for an above-ground or an inground swimming pool or a hot tub (spa)", must be filled in and attached to the required documents. These documents must be submitted to the Division des permis et des inspections, located at 777, boulevard Marcel-Laurin.

### Costs

Fees are required to process a request.

### Location

Above-ground pools are permitted at the following locations:

- Secondary front yard in the case of a corner lot (*figure 1*)
- Side yard
- Rear yard (*figure 2*)

### General provisions

- There must be a minimum distance of 1 meter between the inner wall of the pool and any property line.
- In the case of a private swimming pool located in the secondary front yard, a hedge must be planted along the lot line running along the street. A minimum distance of 1.5 m between the hedge and the sidewalk or street edge must be respected.
- The installation of a swimming pool below an electrical wire or line is prohibited.
- The pool must have a ladder or stairs to step into and out of the water.

### Fencing

- A fence of at least 1.2 metres high must be installed around an above-ground pool.
- The minimum 1.2-m-high fence must also separate any pool from a wall of the main building having direct access to the pool.
- A wall of the main building may be considered to be part of the fence, provided that it has no opening making it possible to directly access the pool enclosure or provided that the opening is equipped with a bar or locking mechanism limiting the opening to 10 cm maximum.
- The fence must be permanently installed in the ground.

Figure 1: Location of an above-ground pool on a corner lot.

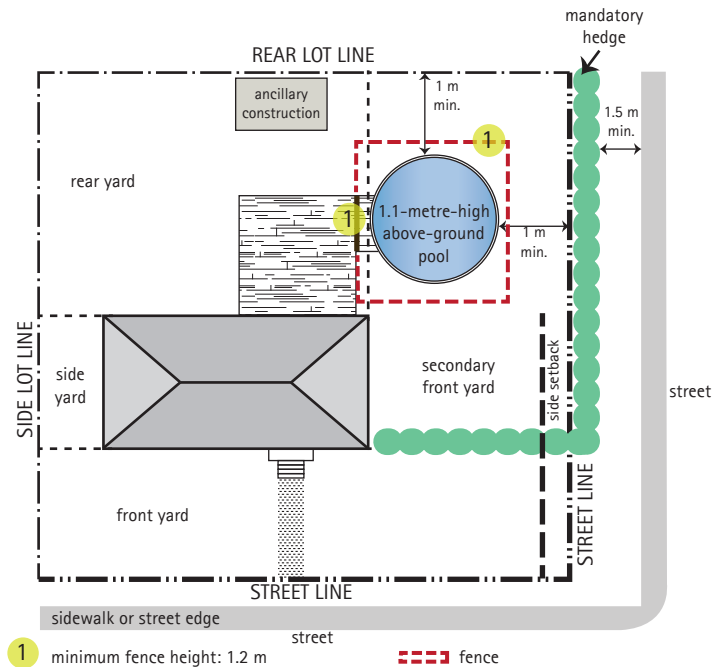
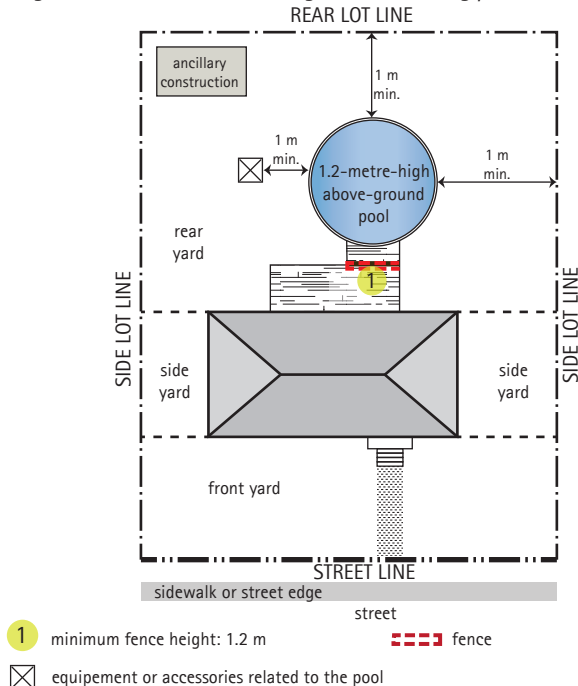

Figure 2: Location of an above-ground swimming pool in a rear yard



### Characteristics (*figure 3*)

- A gate set up in a fence must be equipped with a self-locking passive security device installed on the inner side of the fence, on the upper part of the gate.



# Private pools

## Above-ground swimming pools

- Fence openings must be a maximum of 10 cm.
- The fence must be free of any elements, protrusions or openings which can facilitate climbing.

It is not necessary to fence in an above-ground pool whose sides are at least 1.2 metres high if it is accessible either only by a ladder equipped with a safety gate that shuts and locks automatically OR only by a ladder from a deck or patio whose access to the pool is already protected by a fence that meets the previously mentioned requirements.

Figure 3: Characteristics of a fence around an above-ground pool

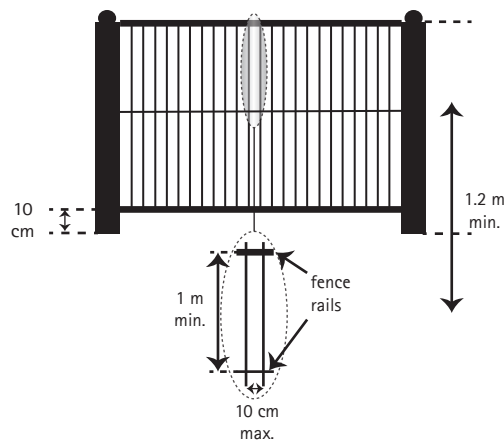

### Equipment and accessories

- Any equipment or accessories related to pool operations must be installed more than 1 metre from the wall of the pool or, as the case may be, from the fence. An accessory may be installed less than 1 metre from the pool or fence only if it is installed inside the fence or in a structure that prevents access to the pool.
- The lines connecting equipment to the pool must be flexible and must not make it possible to climb the wall of the pool or fence.
- Any installations intended to provide or prevent access to the pool must be kept in good operating condition.

The following are prohibited:

- Installing a slide or diving board on an above-ground pool.
- Using a filtration system installation that provides access to an above-ground pool.

### Platform (figure 4)

A platform can be installed around an above-ground pool if the following provisions are respected:

- The platform must be at a height of between 1 m and 1.5 m from the ground.
- A railing, with minimum height of 1.07 m, must surround the platform.
- The platform must be located at least 2 m from all lot lines.

- The platform must have a non-skid surface.

Figure 4: Characteristics of a platform around an above-ground pool (schematic cross-section view)

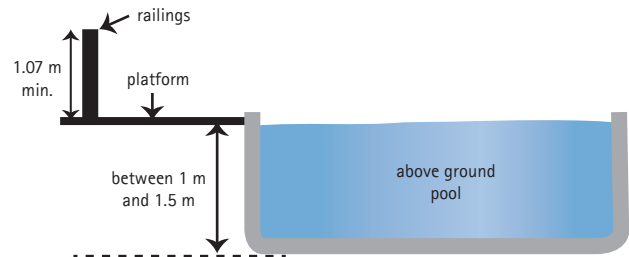

### Gas tank

The installation of a gas tank for gas water heaters is permitted provided the following provisions are respected:

#### Location

- In the side yard and side setback
- In the rear yard and rear setback
- In the rear yard and front setback in the case of a transverse lot\*

\* A lot fronting on 2 parallel streets.

#### Conditions

- The gas tank must be surrounded by a high or low wall, or a fence with a minimum height of 1.5 m, so that it is not visible from the street.
- The maximum height of a gas tank is 2 m.
- The maximum distance between the gas tank and the adjacent wall of the main building is 2 m.
- A maximum encroachment of 2 m on a setback is permitted.
- The minimum distance between the gas tank and any lot line is 2 m. In the case of a side yard and side setback, the minimum distance is 75 cm.

### Lighting

The installation of an above-ground lighting system is permitted if the following provisions are respected:

- The electrical power must be fed underground.
- The light source must only illuminate the lot on which the pool is located.



Information: 311 - [ville.montreal.qc.ca/saint-laurent/infosheets](http://ville.montreal.qc.ca/saint-laurent/infosheets)

Legal framework: Règlement sur le zonage n° RCA08-08-0001  
Règlement sur les tarifs n° RCA14-08-1

Notice: Certain specific provisions, not mentioned in this document, may apply. This information sheet has been prepared for the convenience of the reader and has no official status. Text accuracy is not guaranteed. For legal purposes, consult the official French version of the bylaw and all its amendments.

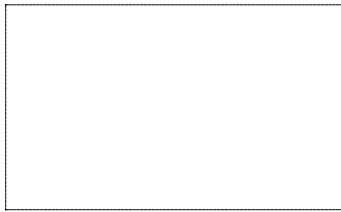

**APPLICATION FOR A CERTIFICATE OF  
AUTHORIZATION FOR AN ABOVE-GROUND OR AN  
INGROUND SWIMMING POOL OR A HOT-TUB (SPA)**

**All fields must be completed and all required documents must be provided and payment made on the date the application is submitted. Incomplete applications will not be considered.**

**Note that zoning clauses must be checked: the zoning Bylaw RCA08-08-0001 and the provincial regulations on swimming pools/hot-tubs**

**REQUIRED DOCUMENTS**

<input type="checkbox"/> <b>2 copies</b> of the site plan indicating the position of the swimming pool/hot-tub on the property, and also indicating the distance between the swimming pool/spa and the property lines, the building, and the fences. Indicate the locations of all accessory equipment such as water heater, filter, fences (type and height), platform and paved surfaces, and the trees on the property and adjacent properties. <b>Also, provide an implantation plan indicating the percentage of green area required by the zoning By-Law.</b>
<input type="checkbox"/> <b>2 copies</b> of the certificate of location, to scale.
<input type="checkbox"/> <b>2 copies</b> of the construction details for an above-ground swimming pool platform, if applicable.
<input type="checkbox"/> The form for the "Application for a certificate of authorization for tree cutting", if applicable.
<input type="checkbox"/> <b>A cheque</b> payable to <b>Ville de Montréal</b> for the amount of: <b>\$80</b> for an above-ground swimming pool or hot-tub; <b>\$316</b> for an in ground or semi-in ground swimming pool.

**1. GENERAL INFORMATION**

Address of the property	
Type of application <input type="checkbox"/> New construction <input type="checkbox"/> Relocation <input type="checkbox"/> Removal	Work value
Type of pool or hot-tub <input type="checkbox"/> Above-ground pool <input type="checkbox"/> In ground pool <input type="checkbox"/> Semi-in ground pool <input type="checkbox"/> Hot-tub	Scheduled work date

**2. NAME OF BUILDING OWNER OR MANAGER**

Name of owner or manager	Contact person
Complete address	Postal code
Telephone	Email address

**3. NAME OF CONTRACTOR**

Name of contractor	Telephone
--------------------	-----------

**4. APPLICANT**

Name	Contact person
Complete address	Postal code
Telephone	Email address

**5. SIGNATURE**

<b>I certify that all of the information I have provided is accurate.</b>	
<b>I acknowledge that any error or omission could result in the cancellation of this application and of the certificate.</b>	
First and last names	
Signature	Date

**A L'USAGE DU BUREAU SEULEMENT**

Approuvé par	Approbation en date	Numéro du certificat d'autorisation
--------------	---------------------	-------------------------------------